

What is VoIP? Making Sense of It

By Lu Myser - VoiceTelOne

A broadband Internet phone company

<http://www.voicetelone.com>

This e-book was written to provide a basic understanding of VoIP (Voice over Internet Protocol). It will provide the reader with a general understanding of what this new technology is about and how it can revolutionize how we use the telephone. It includes a discussion on how VoIP (or sometimes referred to as broadband phone service) differs from traditional telephone service, with a presentation of its advantages and disadvantages.

Copyright © 2007 by VoiceTelOne.com
All Rights Reserved.
Unauthorized distribution or duplication is strictly prohibited.

Copyright Agreement

All material (content) included in "Making Sense of VoIP" (this eBook) is the exclusive property of VoiceTelOne, or its licensors and is protected by copyright and other intellectual property laws. The download of this eBook is intended for the User's personal and noncommercial use. Any other use of the download of this eBook is strictly prohibited. User may not modify, publish, transmit, participate in the transfer or sale of, reproduce, create derivative works from, distribute, perform, display, or in any way exploit any of the content of this eBook in whole or in part. By downloading this eBook, the User acknowledges and agrees to these terms.

Introduction

In today's fast-paced ever-changing technological marketplace it is often difficult to know just how many of the new technologies recently developed might affect our day to day lives. A large number of these new technologies will provide substantial benefits to us, but we will never really notice them. Many of these new technologies are simply merged into existing products and services we use every day. We often see them as new features, enhanced performance, or improved reliability.

Occasionally a new and revolutionary technology will emerge to stand out from all the rest. Take the original telephone for example. Look at how this new (in 1876) relatively simple technology completely revolutionized the way we communicate. No one at that time had any idea just how revolutionary this technology would become.

In more modern times, we've seen how cell phone technology has once again revolutionized the way we communicate. In its early days, cell phone technology was available to only a select few that could justify the hefty cost. Market demands and competition have dramatically driven down costs to where it is affordable to just about anyone. Today it's rare to find anyone who doesn't have a cell phone either clipped to their side or bouncing around in their purse. We are all familiar with the benefits of mobility that makes the cell phone such a revolutionary technology.

VoIP technology has the ability to be just as revolutionary. More and more, Internet users are switching to high-speed, broadband connections like cable, DSL, and wireless. Those that understand what VoIP is and how it can save them a bundle each month on their phone bill are making the switch. They are saying goodbye to their traditional telephone companies and costly phone bills forever! And make no mistake, traditional telephone companies are running scared as millions have already made the switch. In time, traditional telephone companies will be a thing of the past. Now that is truly revolutionary.

Are you ready to say goodbye to your traditional telephone company and all their exorbitant costs associated basic service, as well as each additional calling feature?

In this document, I hope to shed some light on what VoIP is all about and the benefits it can provide. It is not meant to be an in-depth technical discussion of VoIP technology, rather a more simplified explanation of VoIP as it applies simply to making and receiving phone calls over the Internet. Well, maybe just a bit technical in the beginning to get a few concepts out of the way.

What is VoIP?

In a nutshell, VoIP is a technology that allows you to make and receive phone calls through your high-speed (broadband) Internet connection instead of through traditional telephone lines. VoIP provides the same or better voice quality as traditional telephone lines, but you pay far less for all of your calls worldwide. This is because your calls travel over the Internet (which belongs in the public domain) instead of costly long-distance telephone lines owned by the phone companies.

Making and receiving calls with VoIP is virtually the same we're accustomed to with traditional telephone service. You simply pick up the handset, hear dial tone, and dial any phone number anywhere in the world. For incoming calls, the phone rings and you answer the call as you always have. It works exactly the same!

Technically Speaking...

VoIP is an acronym for "Voice over IP", or sometimes also called "Voice over Internet Protocol".

Internet Protocol (IP) is the basic protocol software used for the Internet. It is a standardized method of sending information across the Internet embedded in packets of data. This protocol is what allows us to browse websites, send and receive email, etc. "Voice" over IP is simply a process allowing digital voice signals to be sent over the Internet using these same data packets.

Although VoIP has many applications possible beyond just phone service, our discussion in this document is limited to explaining VoIP for basic residential telephone service.

How is VoIP Different?

There are a number of differences between traditional telephone service and VoIP. Aside from the substantial cost savings with VoIP, the most apparent difference is how phone calls are routed between callers.

► Traditional Telephone Service

With traditional telephone service, it can be likened to stringing a pair of copper wires between the two locations (callers) whether they are across the street or across the country. When a connection is made between callers, it is known as circuit. The circuit is accomplished by making multiple connections through a series of switches and copper wire that lay between the two callers. The technology employed to route the call to the other party is called "circuit switching". The enormous network of phone lines and switching equipment used for traditional telephone service is called the Public Switched Telephone Network or simply "PSTN". Figure 1 below is a simplified view of a traditional telephone service connection over the Public Switched Telephone Network.



Figure 1 – Simplified View: Traditional Phone Service

Although traditional phone services via the PSTN have been a standard for well over 100 years, this method of communication is a tremendous waste of resources. This is because a direct connection must be maintained throughout the entire call even during periods of long silence. The calling party essentially owns a dedicated point-to-point connection through the entirety of the call. The cost of the call depends on the length of time (billed in minutes) that the dedicated point-to-point connection is maintained.

► **VoIP Phone Service**

With VoIP, your phone calls are routed over the Internet through a broadband connection rather than phone lines. This method is substantially more efficient. VoIP uses a technology called “packet switching” where the call is broken up into small voice data packets that are sent only as needed between the two parties. This method does not require a dedicated connection as with circuit switching thus freeing up network resources to handle many calls at the same time. The use of data compression further improves this efficiency. Using the Internet as the transport medium, VoIP providers can offer phone services at greatly reduced prices since the majority of the call is routed over the Internet instead of costly long-distance phone lines. Since no one actually owns the Internet, that portion of the call connection is essentially free.

However, VoIP calls are not always routed exclusively over the Internet. VoIP calls are routed depending on the type of phone service the other party being called has. If the call is placed to another VoIP user, the entire call is simply routed end-to-end over the Internet. However, if the call was placed to a standard phone, the call is routed through the Internet to a bridge linking the Internet with the PSTN and then finally to the party being called. Figure 2 is a simplified overview of a VoIP to traditional phone service connection.

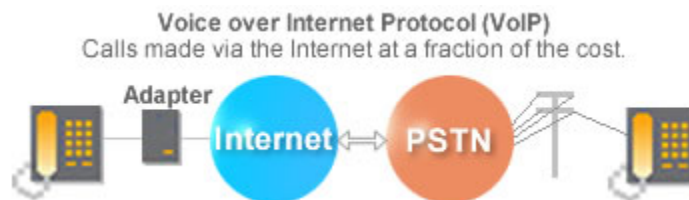

Figure 2 – Overview: VoIP Phone Service to Traditional Phone Service

With VoIP, you plug your phone into your broadband Internet connection instead of the phone jack on the wall supplied by your local phone company.

Standard phones are analog devices designed for use on traditional analog phone lines. The phone produces audio signals in an analog format similar in nature to the audio signals sent from your home stereo unit to the speakers.

Since the internet uses digital technology rather than analog, audio signals from a standard phone must be converted to digital. A device, known as an Analog Telephone Adapter (ATA) is used to accomplish this conversion. See figure 3 below.



Figure 3 – Converting Analog to Digital

Once converted, the digital voice signals are sent over the Internet in data packets much the same as website files and email messages are sent.

With traditional phone lines, when a call is placed, a series of switch connections is made to establish a dedicated connection between the two parties. This is called “circuit switching” and is much like stringing a long telephone line directly between the two parties.

And most VoIP providers include all the same or more calling features like caller ID, call waiting, call forwarding, voicemail, and many more. Unlike most traditional telephone companies who charge extra for each of these calling features, VoIP providers typically include all of these features at no extra charge.

Although the voice quality and reliability can vary dramatically between VoIP providers, in general, most customers will comment that voice quality is as good and is often much better than with their previous traditional phone service.

In cases where you have a cable or high-speed wireless connection that doesn't require a physical telephone line (unlike DSL), you may want to completely get rid of your traditional telephone service to save the high monthly cost associated with just having a telephone line installed whether you use it or not. How nice would it be to call your telephone company and say "You're Fired"?

What You Will Need

At the beginning of this document we stated that it was intended to explain VoIP as it relates to making and receiving phone calls over the Internet. With that said, we will only present information on what is specifically required to make this possible.

By the way, to use VoIP you must have a broadband Internet connection such as DSL, cable, or high-speed wireless. VoIP will not work efficiently over a dialup connection. Although a handful of VoIP providers market a dialup VoIP product, I highly recommend you do not waste your time or money pursuing that technology since it is extremely inefficient and voice quality is very poor and choppy.

In its Simplest Configuration:

- Broadband Internet connection (DSL, Cable, High-Speed Wireless)
- Standard Analog Telephone
- Adaptor (ATA – Analog Telephone Adapter)
- VoIP Provider (such as <http://www.VoiceTelOne.com>)

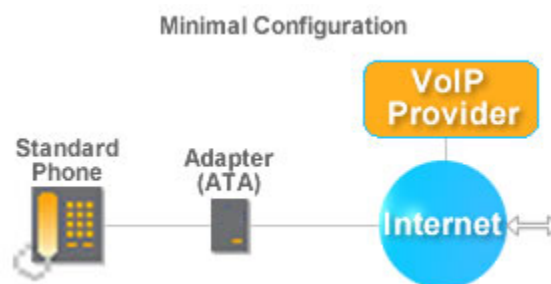

The illustration above shows a standard telephone and adapter directly attached to a broadband Internet connection (broadband modem not shown). This is not however a typical configuration. In a typical configuration, there would be a personal computer already attached to the broadband Internet connection prior to installing a VoIP phone service. There may or may not be a router installed, and sometimes the ATA device will include a built-in router. Note: a router is a device, used to route traffic on a network or between networks. Either way, if two devices are attached to the broadband Internet connection (two computers or a computer and VoIP phone, etc.) a router or similar device must be installed (see below).

A More Typical Configuration:

- Broadband Internet connection (DSL, Cable, High-Speed Wireless)
- Personal Computer
- Router (Standard or Wireless)
- Standard Analog Telephone
- Adaptor (ATA – Analog Telephone Adapter)
- VoIP Provider (such as <http://www.VoiceTelOne.com>)

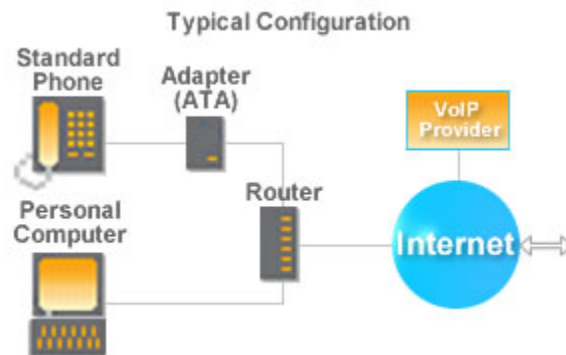

The illustration above shows both a computer and phone w/adaptor connected to a broadband Internet connection through a router. The router can be standard or wireless for connection to the computer, however the phone and ATA device typically plug directly into a port on the back of the router.

Advantages of VoIP

There are a number of advantages for using VoIP over traditional phone service. However, like any new emerging technology, it can be a bit confusing for many. As standards for quality and functionality continue to become established, it will undoubtedly achieve a much greater level of acceptance and become more widely understood by all. It is inevitable that VoIP will eventually replace traditional phone service – in fact, many phone companies are already taking advantage of VoIP technology to offer cheaper long distance rates to their customers. Below are listed a few advantages of VoIP.

- Much cheaper than traditional phone service. Many will save as much as 70% or more each month and have unlimited local and long distance calling. International calling rates are generally much cheaper also.
- VoIP providers generally offer the same or more calling features at no additional charge. These same features can be very expensive with traditional phone service.

- VoIP is portable. You can make and receive phone calls wherever a broadband connection is available. This is a great feature if you travel or are moving since your phone number travels with you.
- If your broadband Internet connection doesn't require a phone line (such as with cable), you can eliminate the standard phone line altogether saving you the cost of just having it installed whether you use it for calling or not.

Disadvantages of VoIP

Although there are plenty of great reasons to switch to VoIP (mainly cost savings) there are a few disadvantages that should be considered. The most notable disadvantages are listed below.

- VoIP phone services do not work during a power outage.
- VoIP phone services do not work if your broadband Internet connection is down.
- 911 emergency services can function much differently than with traditional telephone service. You should check with a potential provider to see how they handle E911 service.
- Voice quality issues can arise – although it is improving all the time. Look for providers that offer a satisfaction guarantee.
- VOIP does not offer you a listing in the telephone book. (However, some may consider this an advantage)

Despite these disadvantages, most VoIP users are still attracted to the huge monthly cost saving and the enhanced features the VoIP service offers.

Things to Consider Before Making the Switch

Can I Really Save Money?

Yes. Of course how much depends on how you currently use your phone. Most VoIP customers will save as much as 50-70% or more over what they are paying their traditional telephone company for local and long-distance service. And, since most VoIP providers include all the same or more calling features at no extra charge, you can save a bundle there also. For those customers making international calls, those rates are generally much cheaper also.

Can I Keep My Same Phone Number?

Yes, in many cases you can. However, it does depend on your traditional telephone company releasing the number and generally takes several business days to complete the transfer. In some cases, your current telephone company may not transfer the number claiming technical reasons among many. This problem is slowly being resolved as they now realize they are required to transfer the numbers when requested.

Do I Need a Broadband Connection?

Yes. To use VoIP you must have a broadband Internet connection such as DSL, cable, or high-speed wireless. The speed of the broadband connection should be at least 100K to avoid voice quality issues. VoIP will not work efficiently over a dialup connection.

How is the Voice Quality?

Better than you might expect. At least most of the time, it is generally considered as good and often much better than traditional telephone service.

What Happens in a Power Outage?

Your VoIP phone service will not function without power, unlike that of traditional telephone service. Although this should be a rare occurrence and does happen, it may be a consideration whether or not you make the switch to VoIP.

To avoid this problem during short power outages, consider plugging your broadband modem, router, and any other phone equipment into a battery backup unit. These units are relative inexpensive and will see you through short periods of power loss.

What About 911 Emergency Service?

This is an important issue that needs to be considered when choosing a VoIP provider. Not all VoIP providers are doing it right. Make sure when selecting a VoIP provider that you determine their level of E911 support.

Now that the Federal Communications Commission has mandated regulations, E911 services will steadily improve and become more standardized. Interestingly, VoIP E911 services will eventually provide much better emergency service information than traditional telephone 911 calls today.

Summary

Most everybody that tries a VoIP Internet phone likes it and is surprised that it actually works just like a traditional telephone. Voice quality is generally better, and lets not forget the huge monthly savings. The added features included free by most VoIP providers, typically equal and often surpass those offered by traditional telephone companies at a substantial cost.

As the VoIP industry continues to mature, it will develop more new and exciting innovations than ever before possible with traditional telephone service. VoIP is expected to become a 20 billion dollar industry within the next 4 years with well over 3 million people already having made the switch.